



**AUSTFLIGHT DRIFTER OWNERS**

**REFERENCE - STIAF - SBC -98-007**

May 7th 1998.

**SPECIAL TECHNICAL INSTRUCTION**

Possible deformation to clevis pin safety ring which attaches rudder cable to front rudder pedals.

This deformation can result from interference contact between the safety ring and the bolt head which secures the ball joint end sleeve to the rudder pedals connecting push rod.

(Referring to illustrations - The bolt is Item 7 on Section 5-13 and the safety ring is Item 3 on Section 5-11.)

**PROBLEM**

Daily inspection of a late production SB aircraft found a deformed safety ring which required replacement. Further inspection found that possible interference contact could exist between the pushrod end sleeve retaining bolt head and safety ring due to allowable rotation around the pushrod ball joints.

**PROCEDURE**

If the condition is found to exist it can be eliminated by realigning the pushrod around its axis and restricting the rotational movement, thereby moving the bolt head from any possible contact with the safety ring.

This is accomplished by firstly loosening the ball joint nut, (refer Item 5 on Section 5-13) rotate pushtube sufficiently to clear bolt head and safety ring. Rotate ball joints (Item 6 on Section 5-13) around their axis until they stop. Then back off slightly so that when locknuts are tightened the pushrod can rotate slightly but bolt head is sufficiently clear of any contact with pin safety ring when pedal is fully back.

**ACTION**

All Drifter model aircraft A503 - A582 and SB inspect before next flight and correct immediately if interference exists.

**MATERIAL**

No material required unless safety ring is deformed in which case it should be replaced.

**ATTACHMENT**

Illustrations Section 5-11 and 5-13



Authorised by: .....

R. Eacott  
Workshop Manager

**Distribution:**

To all Drifter SB owners direct and inclusion in AUF magazine for 95-25 category.

cc: C.A.S.A. Airworthiness Office - Archerfield Brisbane  
A.U.F. Canberra

# Drifter

SECTION 5-11

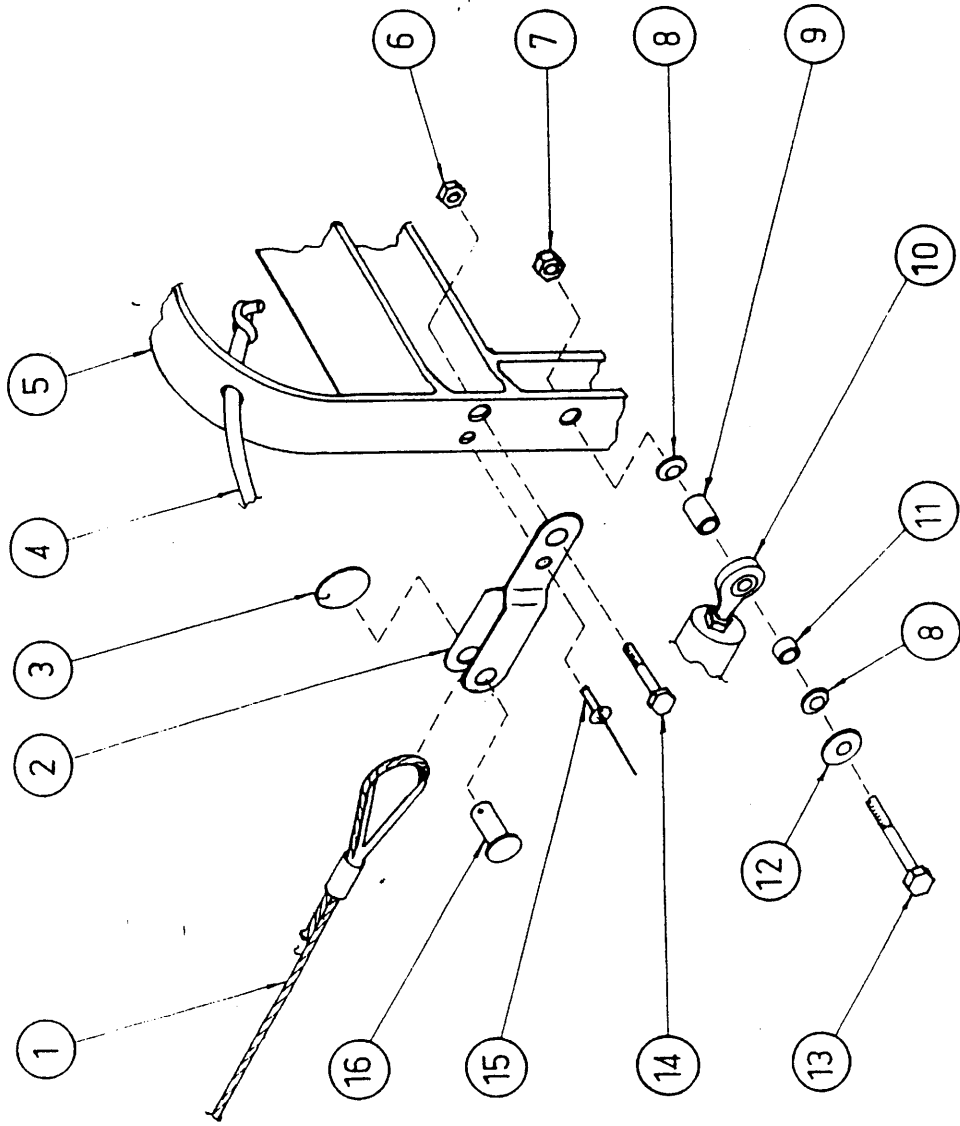

# Drifter

SECTION 5-13

